

1 DECIDUOUS TREE
NTS MS-STD-LS-01

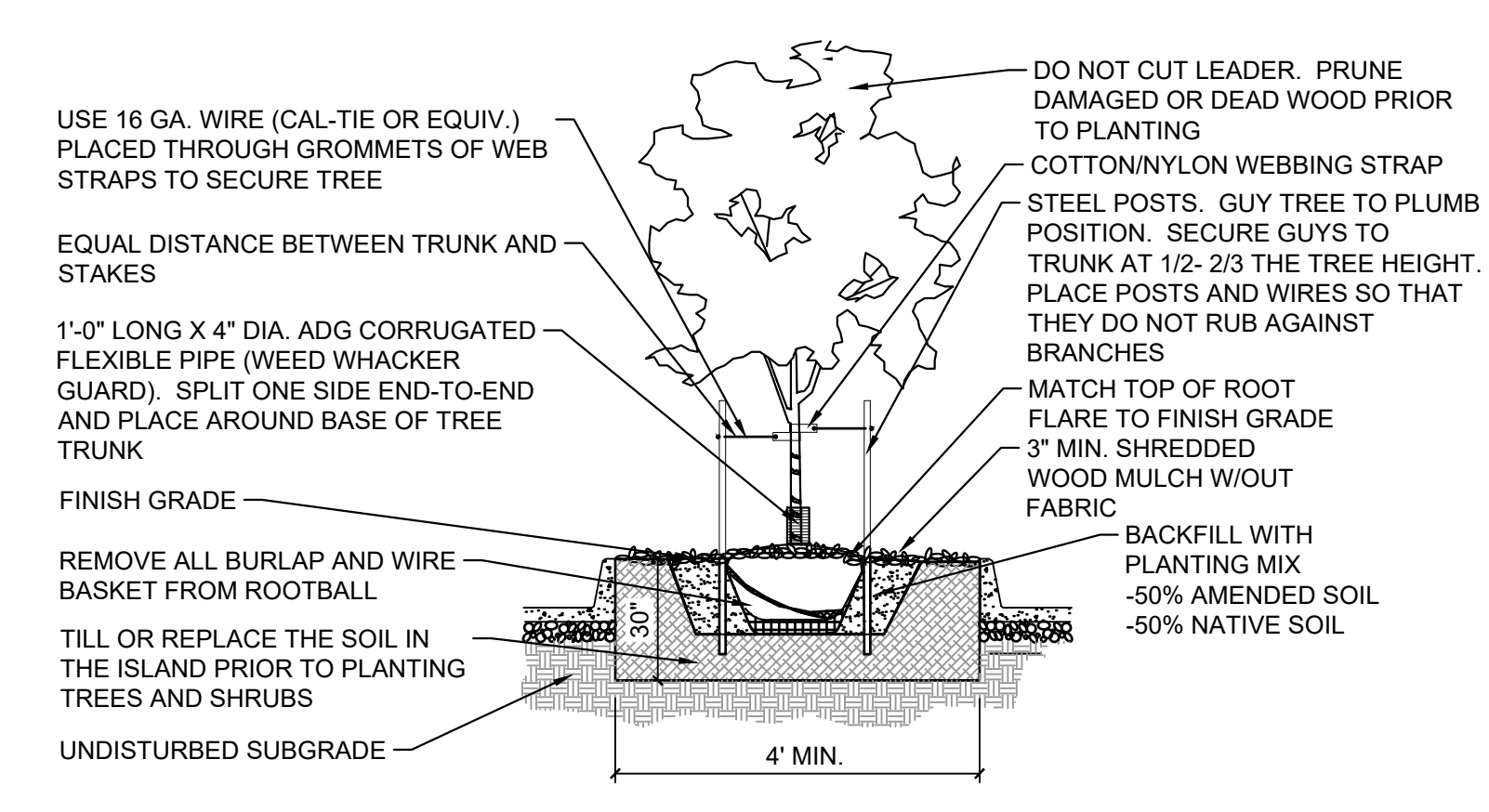

2 PARKING LOT ISLAND TREE
NTS MS-STD-LS-10

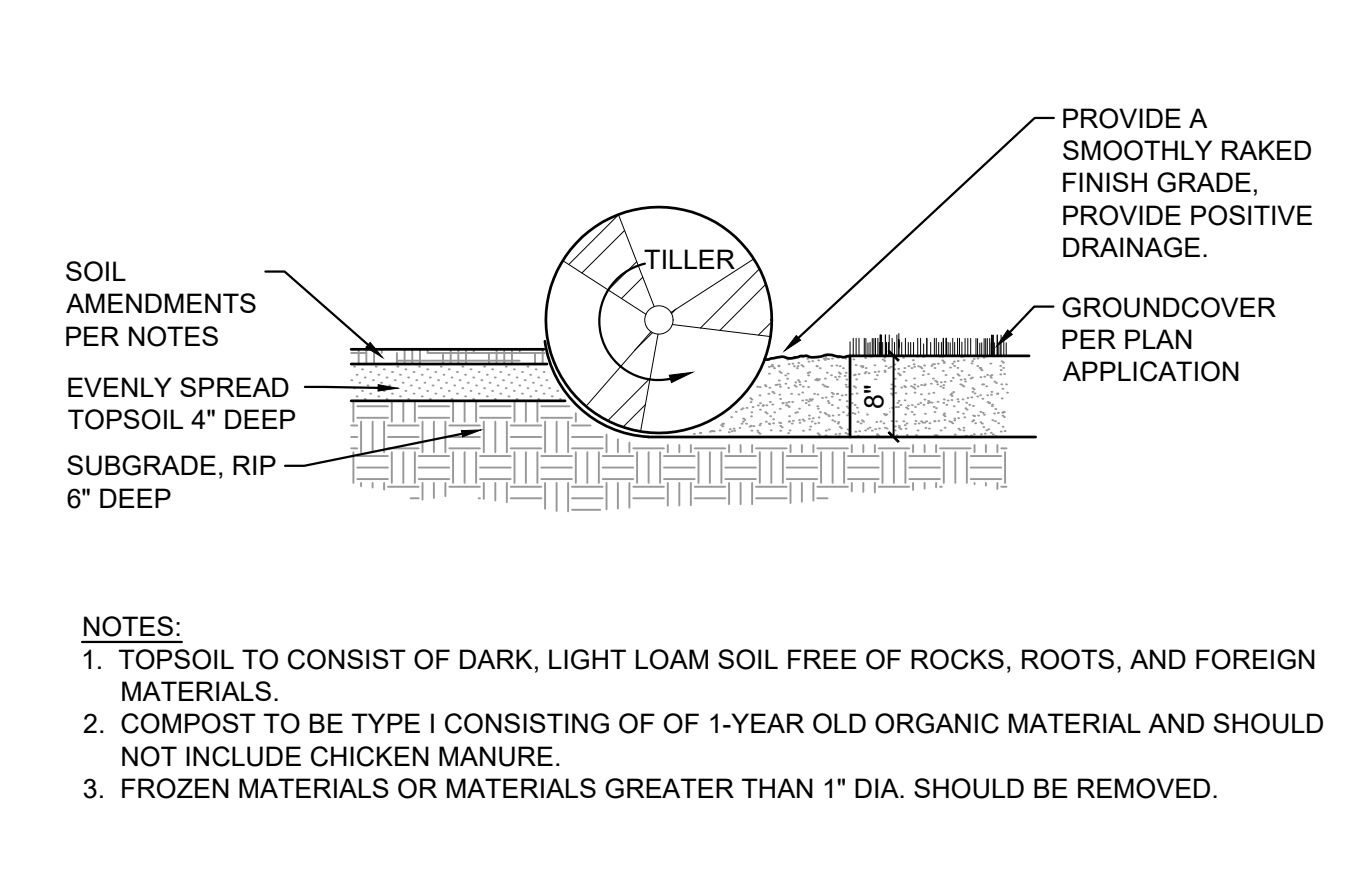

3 SOIL PREP FOR ALL AREAS
NTS MS-STD-LS-05

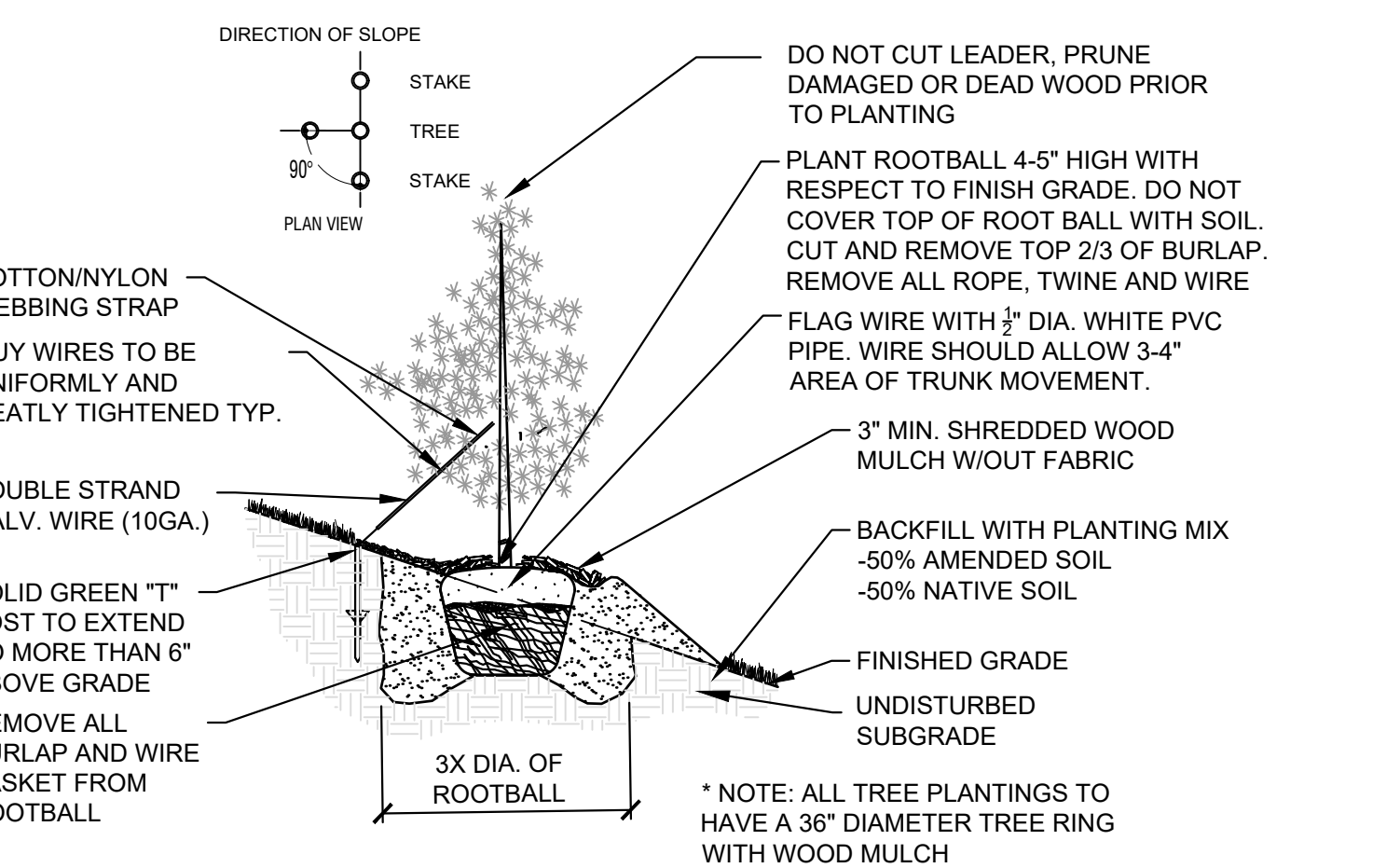

4 EVERGREEN TREE ON SLOPE (3:1 OR STEEPER)
NTS MS-STD-LS-17

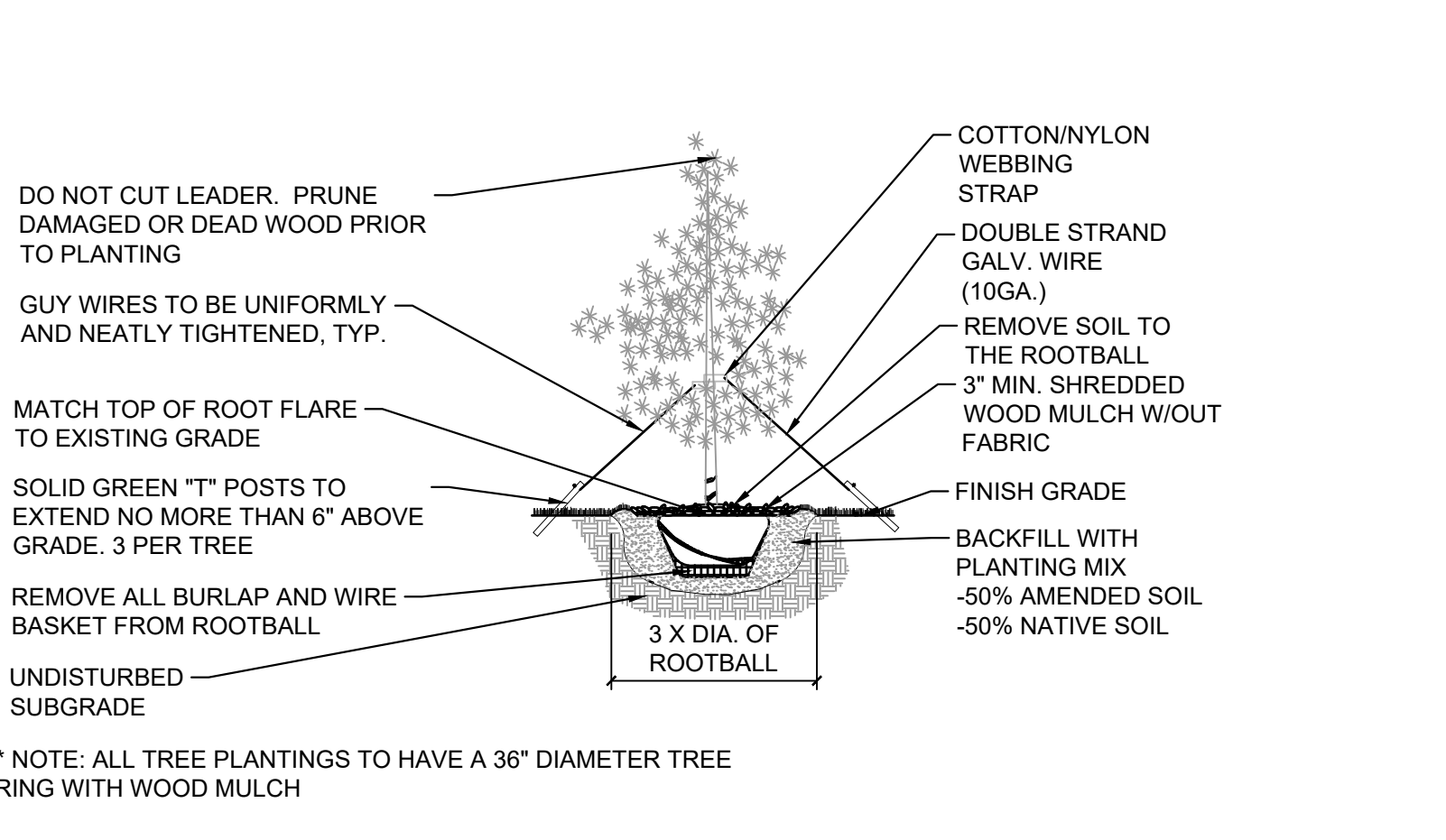

5 EVERGREEN TREE
NTS MS-STD-LS-02

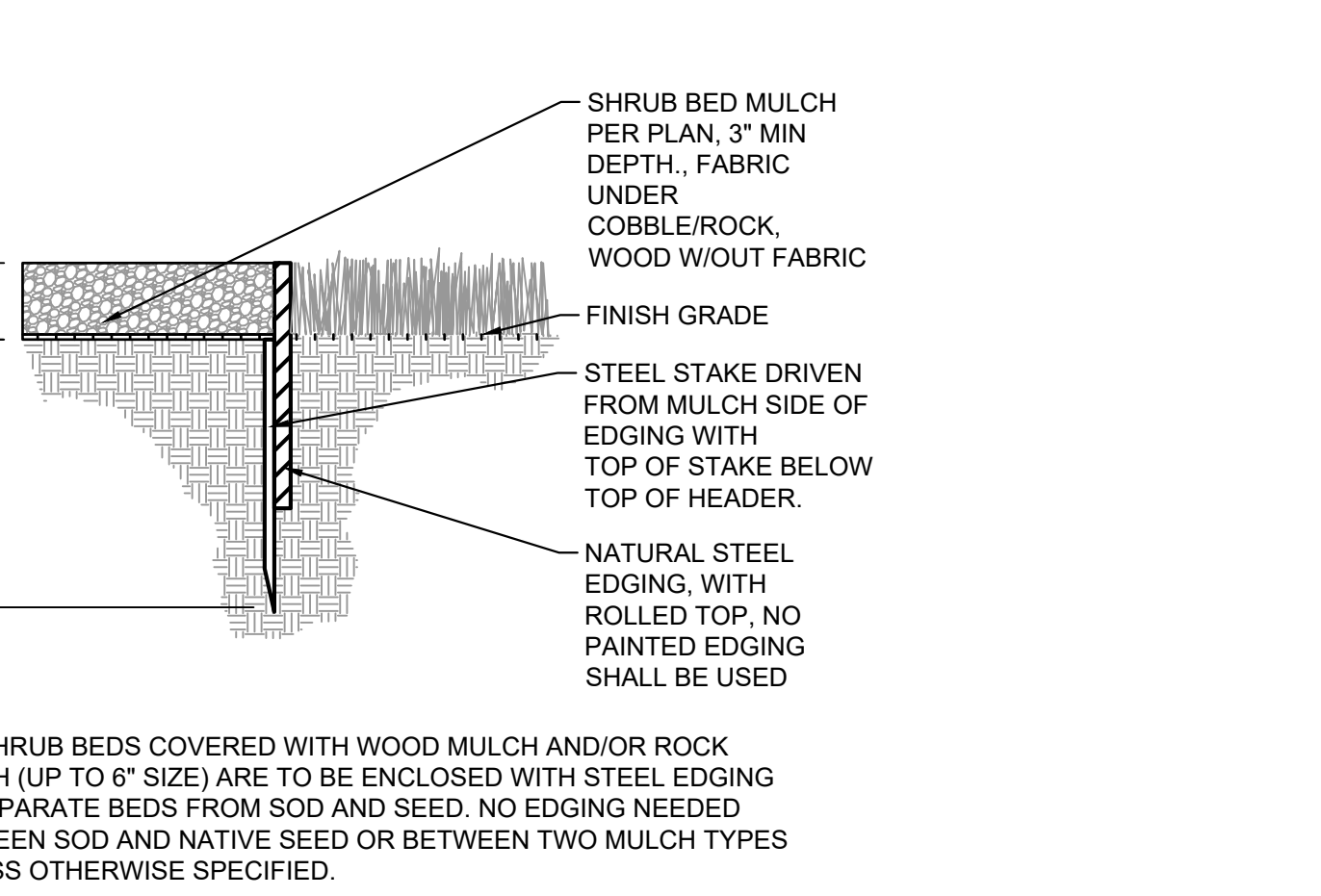

6 STEEL EDGING
NTS MS-STD-LS-12

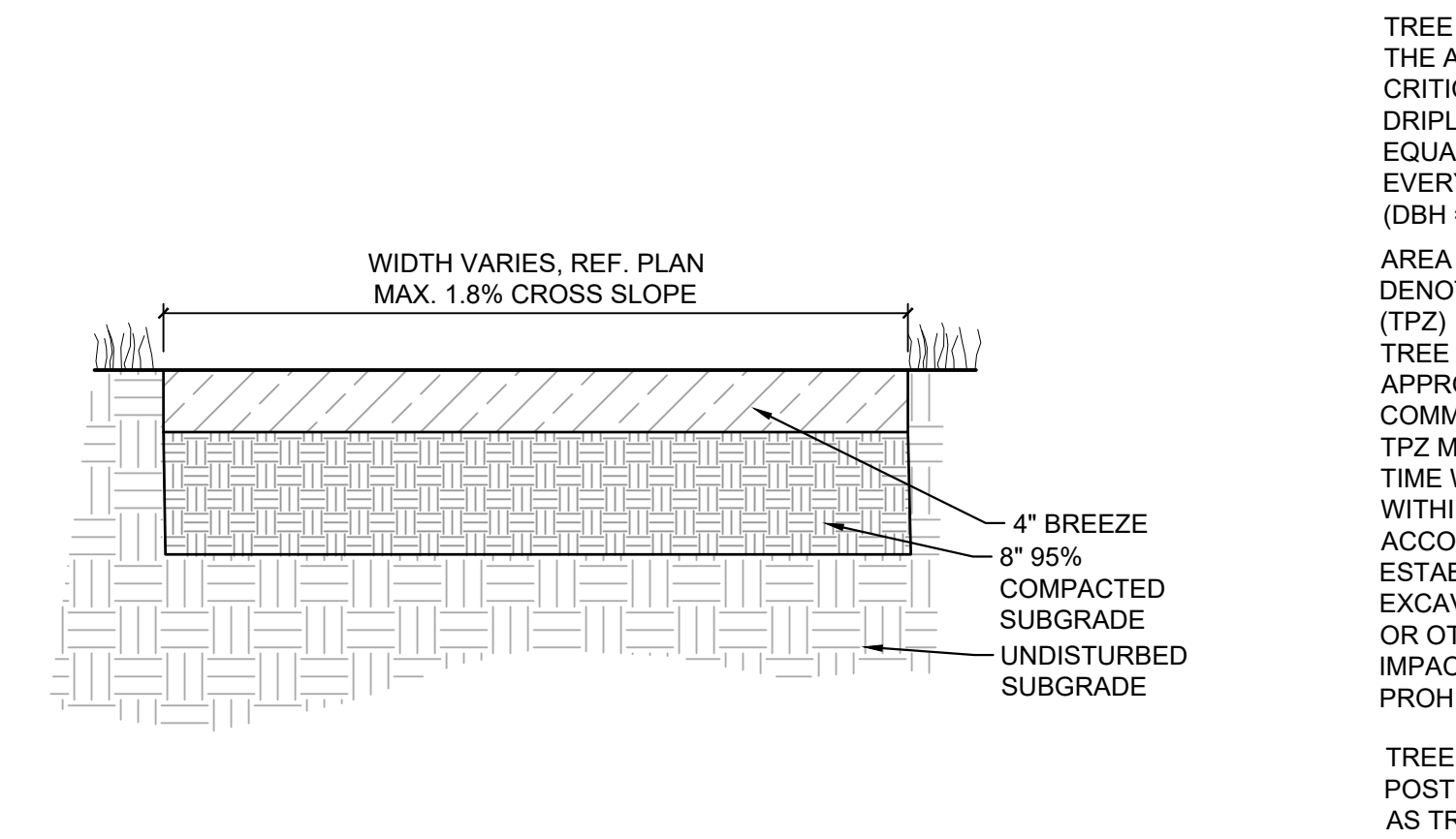

7 SOFT SURFACE TRAIL
NTS MS-STD-PV-14

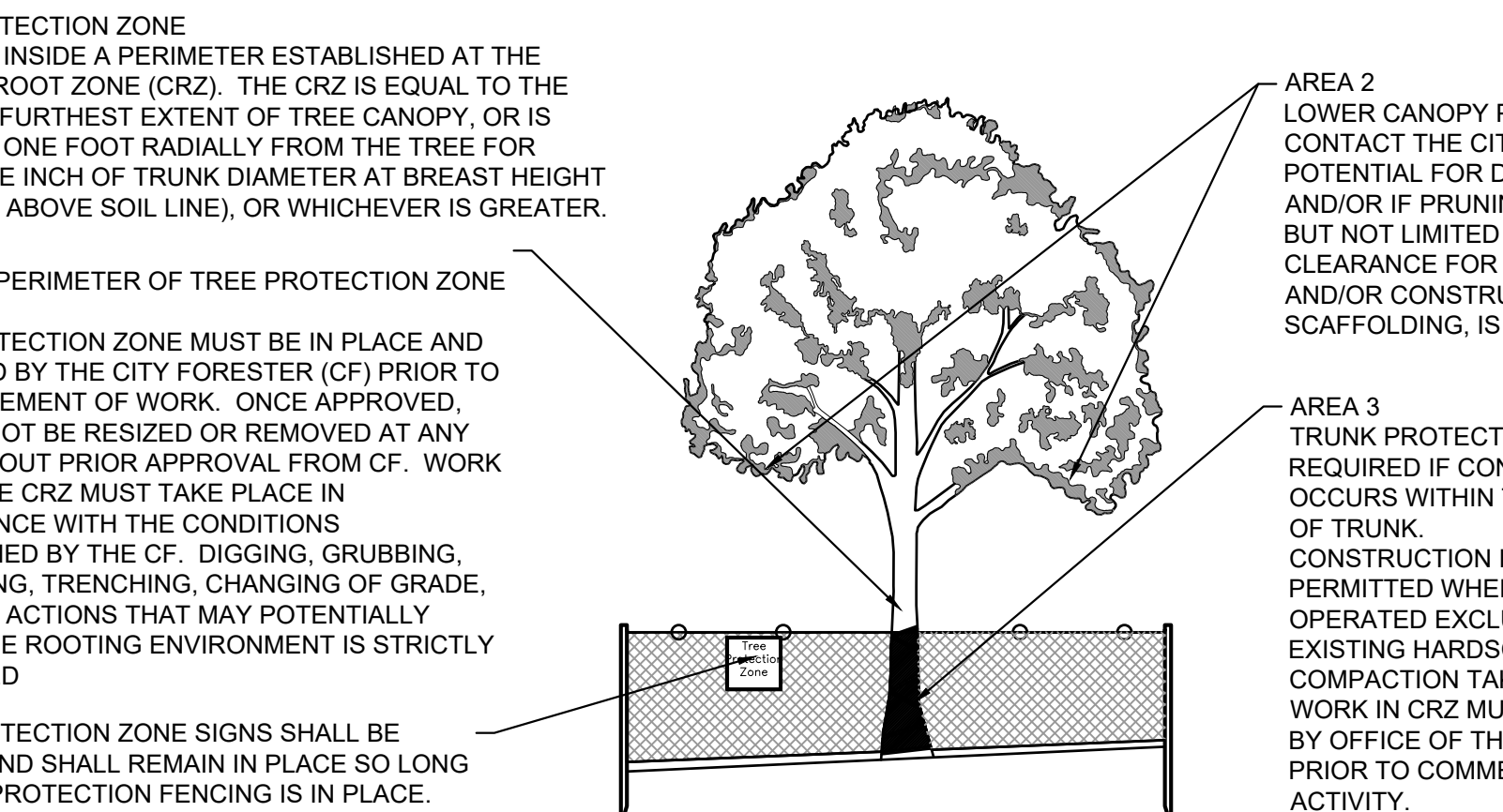

8 EXISTING TREE PROTECTION
NTS MS-STD-LS-11

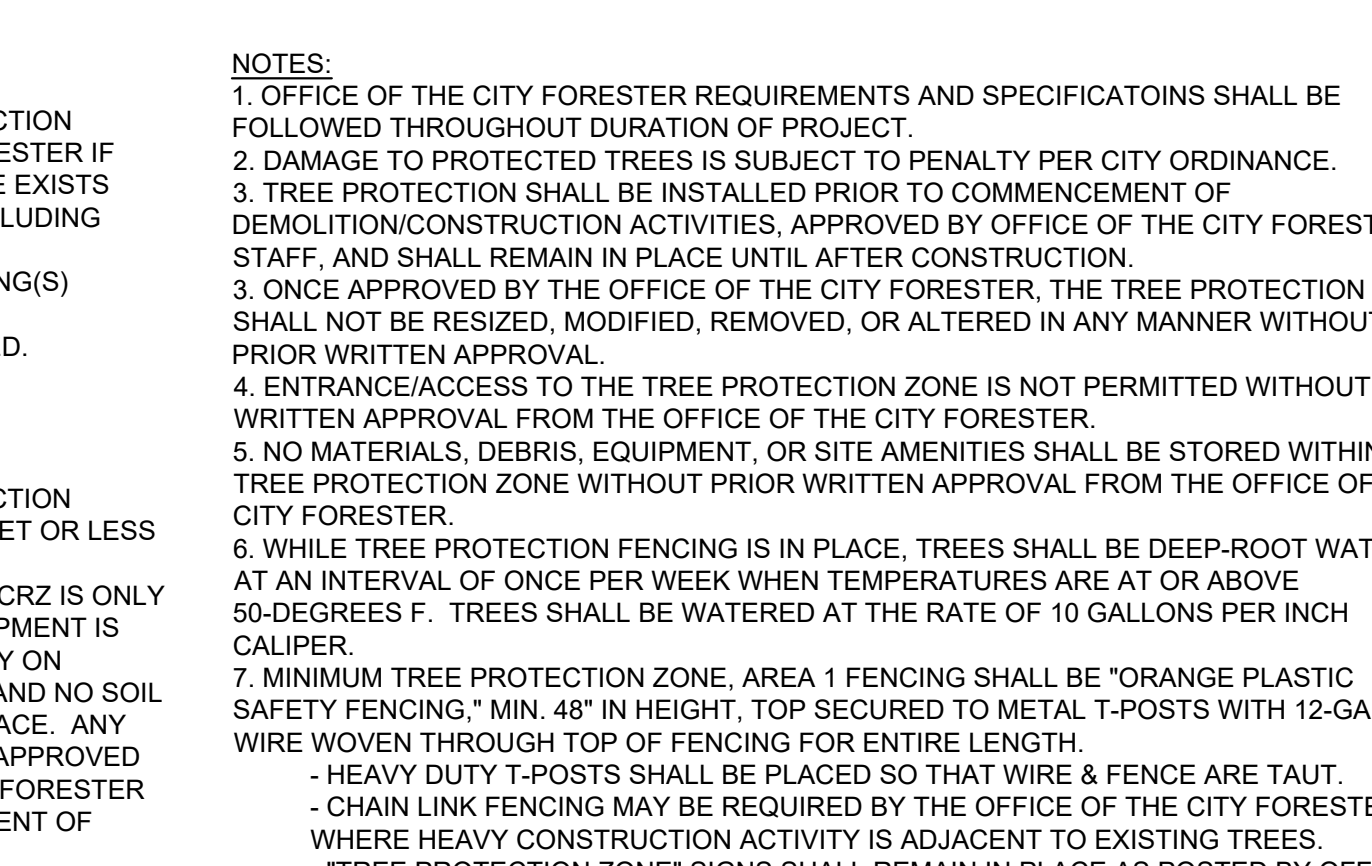

9 STEEL EDGING NOTES
NTS MS-STD-LS-12

CONSULTANTS:

PLANNER/ LANDSCAPE ARCHITECT/ CIVIL ENGINEER:

 2435 RESEARCH PARKWAY, SUITE 300
 COLORADO SPRINGS, CO 80920
 PHONE: (719) 575-0100

OWNER/DEVELOPER:

 4405 ARROWSWEST DRIVE
 COLORADO SPRINGS, CO 80907
 PHONE: (719) 528-2600

4725 S. MONACO STREET, SUITE 100
 DENVER, CO 80237
 PHONE: (303) 860-6654

APPROVAL:

VICINITY MAP:

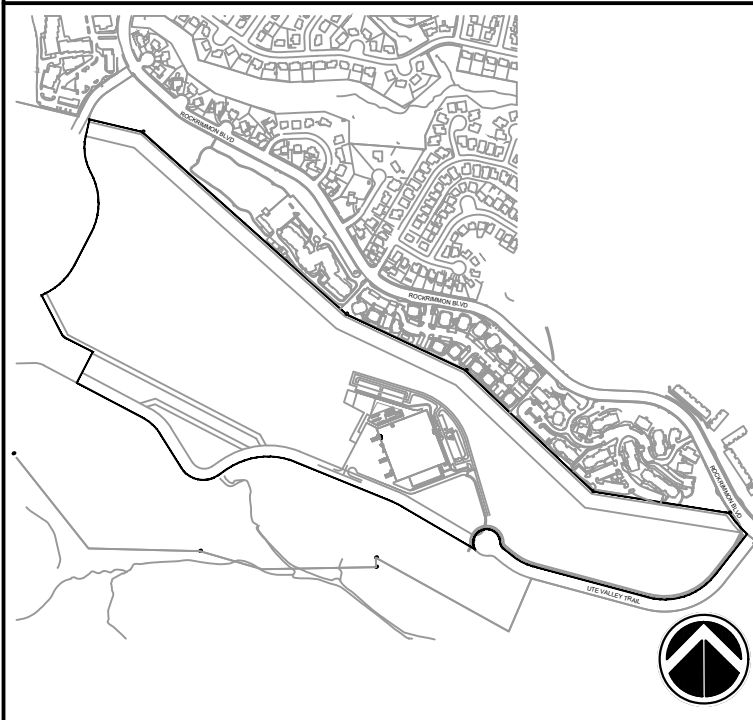

PROJECT:

PROJECT ROCKRIMMON DEVELOPMENT PLAN

COLORADO SPRINGS, CO
MAY 2, 2023

REVISION HISTORY:

NO.	DATE	DESCRIPTION	BY

DRAWING INFORMATION:

PROJECT NO: 23.1078.003
 DRAWN BY: CVW
 CHECKED BY: LCB
 APPROVED BY: JAO
 SHEET TITLE:

PRELIMINARY LANDSCAPE DETAILS

LD02

SHEET 12 OF 20

CITY FILE NO.:

FILE LOCATION: S:\33.1078.003\ENTEGRIS\PROJECT\GARNET1600\CADD\504 PLAN SET\DEVELOPMENT PLAN\LD01.DWG

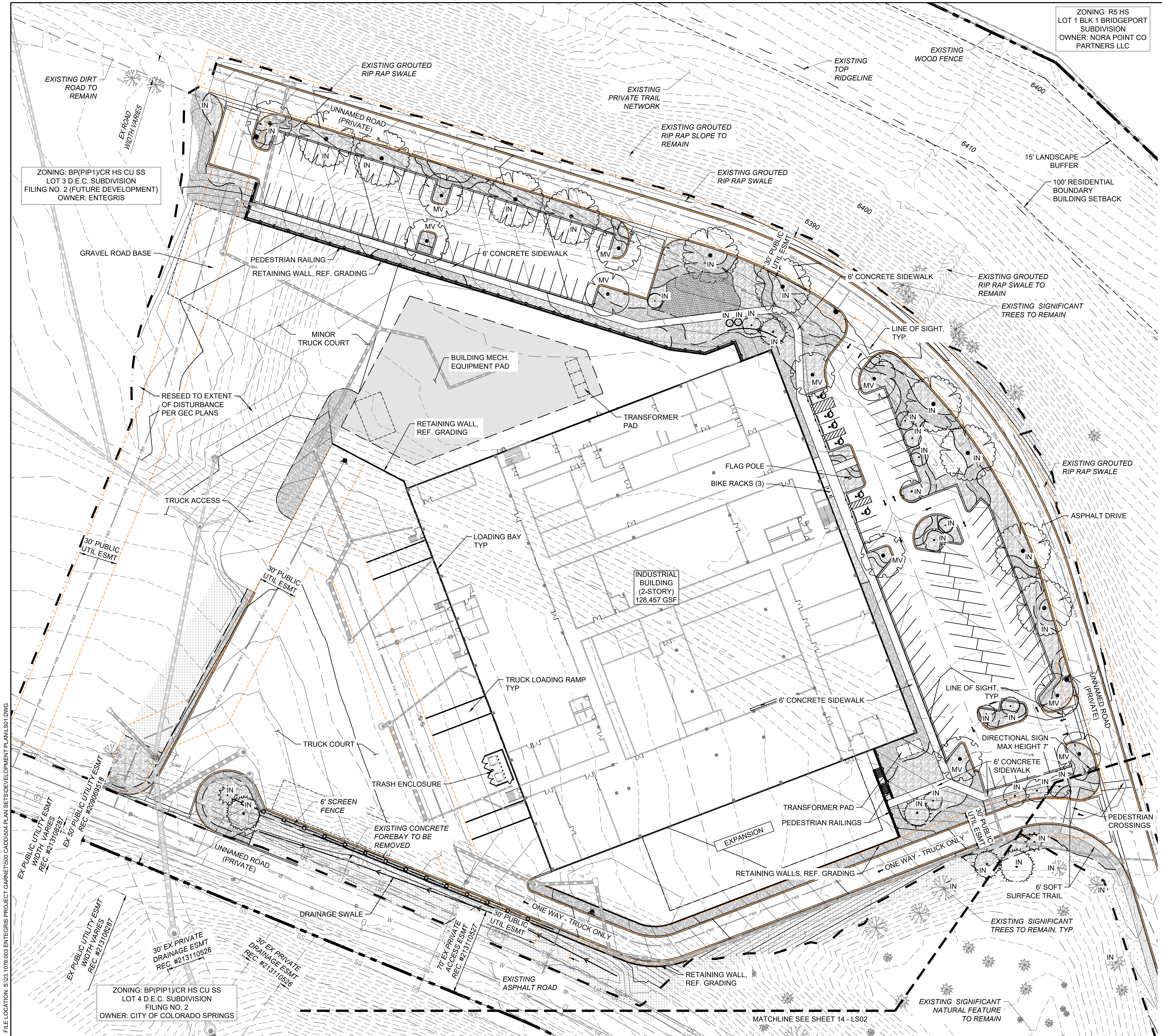

ZONING: R5 HS
 LOT 1 BLK 1 BRIDGEPORT
 SUBDIVISION
 OWNER: NORA POINT CO
 PARTNERS LLC

ZONING: BP(PIP1)CR HS CU SS
 LOT 3 D.E.C. SUBDIVISION
 FILING NO. 2 (FUTURE DEVELOPMENT)
 OWNER: ENTEGRIS

ZONING: BP(PIP1)CR HS CU SS
 LOT 4 D.E.C. SUBDIVISION
 FILING NO. 2
 OWNER: CITY OF COLORADO SPRINGS

LEGEND

	3/4" ROCK MULCH TYPE: SUPPLIER: DEPTH: OR APPROVED EQUAL	26,435 SF
	4-6" COBBLE TYPE: SUPPLIER: DEPTH: OR APPROVED EQUAL	20,569 SF
	NATIVE SEED-LOW MIX NAME: SUPPLIER: OR APPROVED EQUAL	4,694 SF
	NATIVE SEED-TALL MIX NAME: SUPPLIER: OR APPROVED EQUAL	20,533 SF
	BREEZE COLOR: SUPPLIER: DEPTH: OR APPROVED EQUAL	2,741 SF
	SOD	1,776 SF
	EXISTING DECIDUOUS TREE - TO REMAIN	
	EXISTING EVERGREEN TREE - TO REMAIN	

2023-05-02 09:04

CONSULTANTS:
 PLANNER/ LANDSCAPE ARCHITECT/ CIVIL ENGINEER:

Matrix
 2435 RESEARCH PARKWAY, SUITE 300
 COLORADO SPRINGS, CO 80920
 PHONE: (719) 575-0100

Entegris
 4405 ARROWSWEST DRIVE
 COLORADO SPRINGS, CO 80907
 PHONE: (719) 528-2600

WEITZ
 4725 S. MONACO STREET, SUITE 100
 DENVER, CO 80237
 PHONE: (303) 860-6654

APPROVAL:

VICINITY MAP:

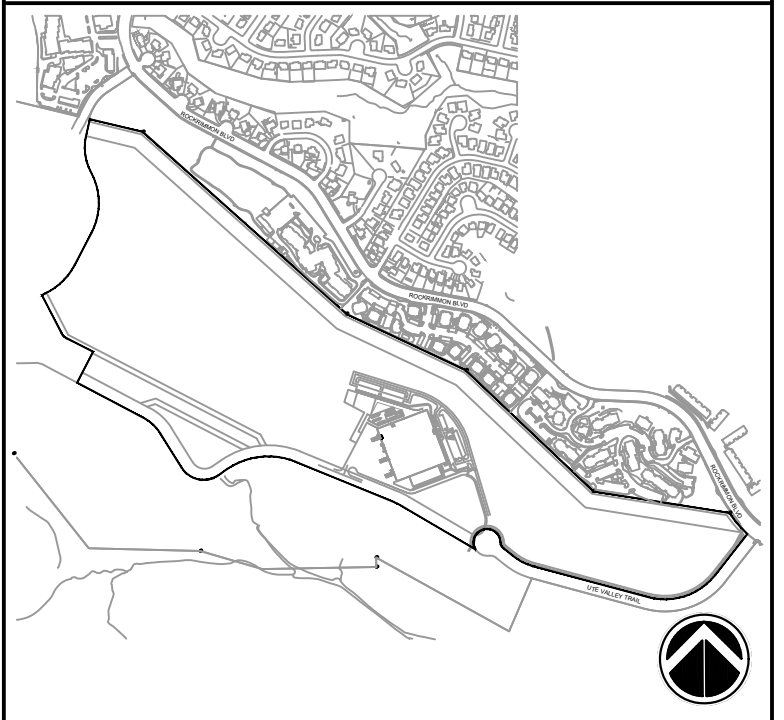

PROJECT:
**PROJECT ROCKRIMMON
 DEVELOPMENT PLAN**

COLORADO SPRINGS, CO
 MAY 2, 2023

REVISION HISTORY:

NO.	DATE	DESCRIPTION	BY

DRAWING INFORMATION:
 PROJECT NO: 23.1078.003
 DRAWN BY: CVW
 CHECKED BY: LCB
 APPROVED BY: JAO
 SHEET TITLE:

**PRELIMINARY
 LANDSCAPE PLAN**

LS01
 SHEET 13 OF 20

CITY FILE NO.:

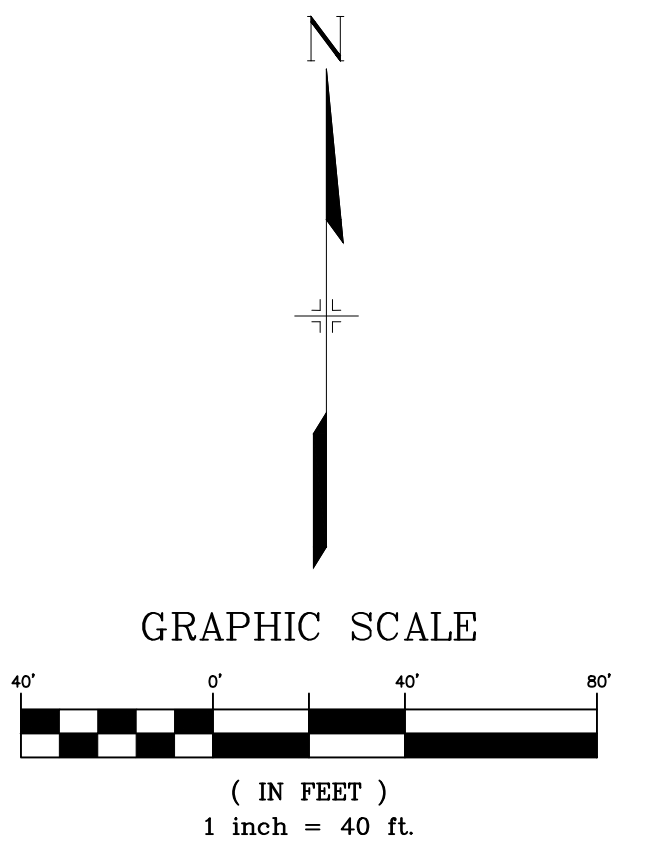

FILE LOCATION: S:\33.1078.003\ENTEGRIS PROJECT\ROCKRIMMON CAD\604 PLAN SETS\DEVELOPMENT PLAN\LS01.DWG

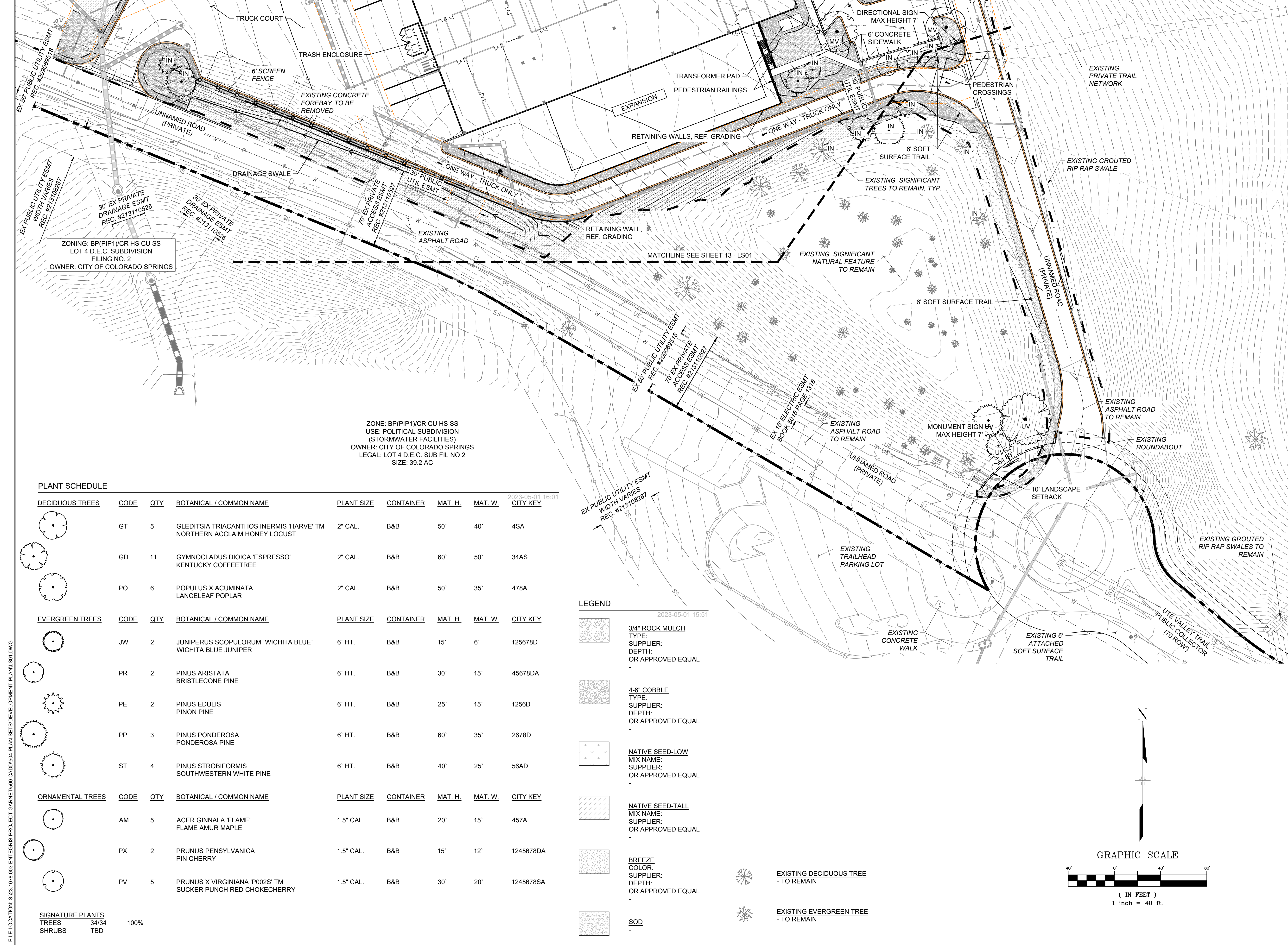

ZONING: BP(PIP1)CR HS CU SS
 LOT 4 D.E.C. SUBDIVISION
 FILING NO. 2
 OWNER: CITY OF COLORADO SPRINGS

ZONE: BP(PIP1)CR CU HS SS
 USE: POLITICAL SUBDIVISION
 (STORMWATER FACILITIES)
 OWNER: CITY OF COLORADO SPRINGS
 LEGAL: LOT 4 D.E.C. SUB FIL NO 2
 SIZE: 39.2 AC

PLANT SCHEDULE

DECIDUOUS TREES	CODE	QTY	BOTANICAL / COMMON NAME	PLANT SIZE	CONTAINER	MAT. H.	MAT. W.	CITY KEY
	GT	5	GLEDITSIA TRIACANTHOS INERMIS 'HARVE' TM NORTHERN ACCLAIM HONEY LOCUST	2" CAL.	B&B	50'	40'	4SA
	GD	11	GYMNOCLADUS DIOICA 'ESPRESSO' KENTUCKY COFFEETREE	2" CAL.	B&B	60'	50'	34AS
	PO	6	POPULUS X ACUMINATA LANCELEAF POPLAR	2" CAL.	B&B	50'	35'	478A
EVERGREEN TREES	CODE	QTY	BOTANICAL / COMMON NAME	PLANT SIZE	CONTAINER	MAT. H.	MAT. W.	CITY KEY
	JW	2	JUNIPERUS SCOPULORUM 'WICHITA BLUE' WICHITA BLUE JUNIPER	6' HT.	B&B	15'	6'	125678D
	PR	2	PINUS ARISTATA BRISTLECONE PINE	6' HT.	B&B	30'	15'	45678DA
	PE	2	PINUS EDULIS PINON PINE	6' HT.	B&B	25'	15'	1256D
	PP	3	PINUS PONDEROSA PONDEROSA PINE	6' HT.	B&B	60'	35'	2678D
	ST	4	PINUS STROBIFORMIS SOUTHWESTERN WHITE PINE	6' HT.	B&B	40'	25'	56AD
ORNAMENTAL TREES	CODE	QTY	BOTANICAL / COMMON NAME	PLANT SIZE	CONTAINER	MAT. H.	MAT. W.	CITY KEY
	AM	5	ACER GINNALA 'FLAME' FLAME AMUR MAPLE	1.5" CAL.	B&B	20'	15'	457A
	PX	2	PRUNUS PENNSYLVANICA PIN CHERRY	1.5" CAL.	B&B	15'	12'	1245678DA
	PV	5	PRUNUS X VIRGINIANA 'P002S' TM SUCKER PUNCH RED CHOKECHERRY	1.5" CAL.	B&B	30'	20'	1245678SA

SIGNATURE PLANTS
 TREES 34/34 100%
 SHRUBS TBD

LEGEND

- 3/4" ROCK MULCH
TYPE:
SUPPLIER:
DEPTH:
OR APPROVED EQUAL
- 4-6" COBBLE
TYPE:
SUPPLIER:
DEPTH:
OR APPROVED EQUAL
- NATIVE SEED-LOW
MIX NAME:
SUPPLIER:
OR APPROVED EQUAL
- NATIVE SEED-TALL
MIX NAME:
SUPPLIER:
OR APPROVED EQUAL
- BREEZE
COLOR:
SUPPLIER:
DEPTH:
OR APPROVED EQUAL
- SOD
- EXISTING DECIDUOUS TREE
- TO REMAIN
- EXISTING EVERGREEN TREE
- TO REMAIN

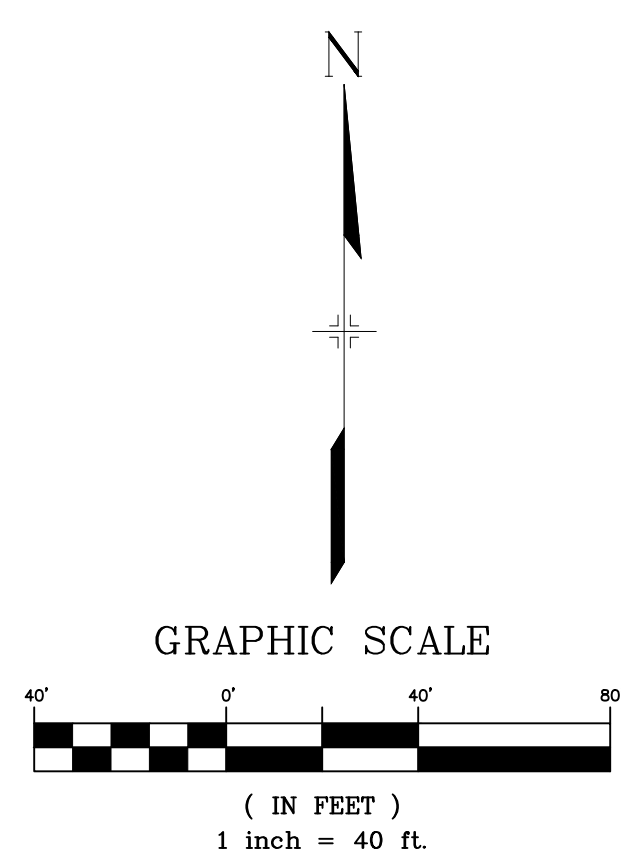

CONSULTANTS:
 PLANNER/ LANDSCAPE ARCHITECT/ CIVIL ENGINEER:
Matrix
 2435 RESEARCH PARKWAY, SUITE 300
 COLORADO SPRINGS, CO 80920
 PHONE: (719) 575-0100

OWNER/DEVELOPER:

 4405 ARROWSWEST DRIVE
 COLORADO SPRINGS, CO 80907
 PHONE: (719) 528-2600

 4725 S. MONACO STREET, SUITE 100
 DENVER, CO 80237
 PHONE: (303) 860-6654

APPROVAL:

 VICINITY MAP:

PROJECT:
**PROJECT ROCKRIMMON
 DEVELOPMENT PLAN**
 COLORADO SPRINGS, CO
 MAY 2, 2023

REVISION HISTORY:

NO.	DATE	DESCRIPTION	BY

DRAWING INFORMATION:
 PROJECT NO: 23.1078.003
 DRAWN BY: CVW
 CHECKED BY: LCB
 APPROVED BY: JAO
 SHEET TITLE:

**PRELIMINARY
 LANDSCAPE PLAN**

LS02

SHEET 13 OF 20

CITY FILE NO.:

FILE LOCATION: S:\33_1078_003_ENTEGRIS_PROJECT_GARNET\600_CADD\604_PLAN_SETS\DEVELOPMENT_PLANS\LS01.DWG

FILE LOCATION: S:\33.1078.003\ENTEGRIS PROJECT\GARNET1600 CAD\1604 PLAN SET\DEVELOPMENT PLANS\SA01.DWG



SITE LEGEND

- PROPOSED CONTOURS
- EXISTING CONTOURS
- PROPERTY BOUNDARY
- PROPOSED CONCRETE PANEL WALL/ MODULAR BLOCK RETAINING WALL

ENVIRONMENTAL IMPACTS LEGEND

- EXISTING VEGETATIVE AREA
- EXISTING SLOPES GREATER THAN 25%

SOIL LEGEND

- CHASEVILLE-MIDWAY COMPLEX
- RAZOR CLAY LOAM (3%-9% SLOPES)
- TRAVESSILLA-ROCK OUTCROP COMPLEX (8%-90% SLOPES)

NOTES:

1. THE HYDROLOGIC SOIL GROUP FOR THE MAJORITY OF THE PROPERTY CONSISTS OF SOIL GROUP D PER THE NRCS SOIL RESOURCE REPORT DATED FEBRUARY 2023. SOIL GROUP D CONSISTS OF SOILS HAVING A VERY SLOW INFILTRATION RATE WHEN THOROUGHLY WET. THESE CONSIST CHIEFLY OF CLAYS THAT HAVE A HIGH SHRINK-SWELL POTENTIAL, SOILS THAT HAVE A HIGH WATER TABLE, SOILS THAT HAVE A CLAYPAN OR CLAY LAYER AT OR NEAR THE SURFACE, AND SOILS THAT ARE SHALLOW OVER NEARLY IMPERVIOUS MATERIAL. THESE SOILS HAVE A VERY SLOW RATE OF WATER TRANSMISSION.

CONSULTANTS:

PLANNER/ LANDSCAPE ARCHITECT/ CIVIL ENGINEER:



2435 RESEARCH PARKWAY, SUITE 300
 COLORADO SPRINGS, CO 80920
 PHONE: (719) 575-0100

OWNER/DEVELOPER:



4405 ARROWSWEST DRIVE
 COLORADO SPRINGS, CO 80907
 PHONE: (719) 528-2600



4725 S. MONACO STREET, SUITE 100
 DENVER, CO 80237
 PHONE: (303) 860-6654

APPROVAL:

VICINITY MAP:

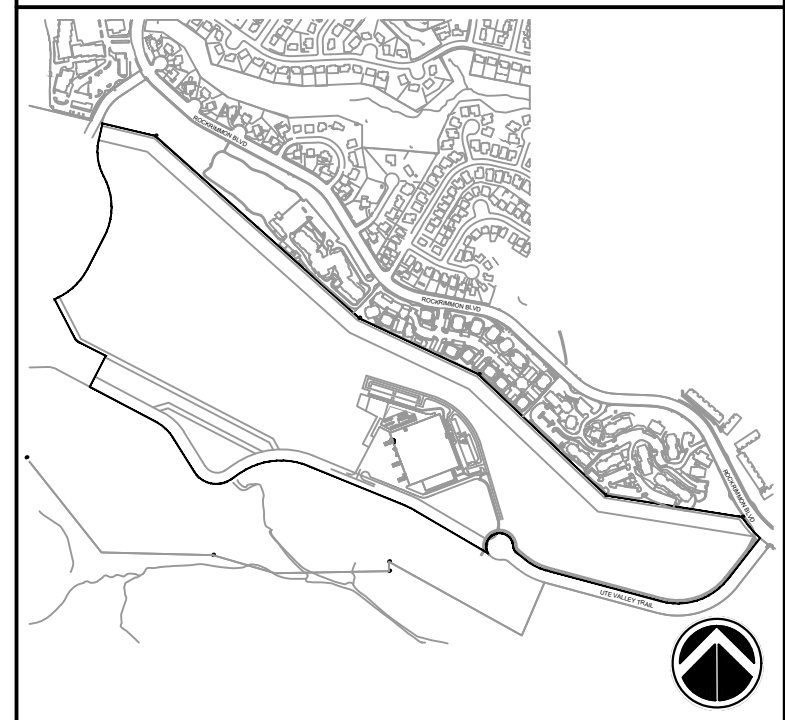

PROJECT:

PROJECT ROCKRIMMON DEVELOPMENT PLAN

**COLORADO SPRINGS, CO
 MAY 2, 2023**

REVISION HISTORY:

NO.	DATE	DESCRIPTION	BY

DRAWING INFORMATION:

PROJECT NO: 23.1078.003

DRAWN BY: CVW

CHECKED BY: LCB

APPROVED BY: JAO

SHEET TITLE:

LAND SUITABILITY ANALYSIS COMPOSITE

SA01

SHEET 15 OF 20

CITY FILE NO.:

GRAPHIC SCALE

